



**NORTH PENDER ISLAND LOCAL TRUST COMMITTEE  
TEMPORARY USE PERMIT  
NP-TUP-2023.5 (Grimmer)**

**4415 Bedwell Harbour Road**

To: Barbara and Glenn Grimmer  
c/o Aaron Grimmer

1. This Permit applies to the land described below:

That portion of:

Lot 1, Section 18, Pender Island, Cowichan District, Plan VIP59806  
(PID: 018-948-421).

Indicated as 'Temporary Use Area' on Schedule 'A' attached to and forming part of this permit.

2. This permit is issued for the purpose of permitting the owner to conduct the following uses and no others in the Temporary Use Area of the property:

- a) A concrete batch plant operation.
- b) The storage, handling and wholesale of aggregates defined as sand, drainage rock and gravel.
- c) For certainty, and for the purposes of this permit, handling is defined as blending, but does not include screening, sorting, crushing or washing.
- d) Storage of motorized and non-motorized vehicles and equipment directly required for the concrete and excavation business know as "Gulf Excavating Ltd".

3. This permit allows the following existing buildings and structures as shown on Schedule 'A'.

- a) Buildings and structures accessory to the uses permitted in Section 2. (above) and as shown on Schedule 'A' attached to and forming part of this permit and specified as follows:
  - i. One (1) concrete hopper;
  - ii. One (1) 'Pull in Bay' constructed of concrete 'lock-blocks';
  - iii. Impermeable wastewater holding tanks, and a retention pond adequate in number and capacity for wastewater collection and recycling for the concrete batch operation;
  - iv. One (1) fuel storage building ('sea container');
  - v. One (1) Maintenance Structure (fabric/'coverall' type) a with maximum area of 463.6 m<sup>2</sup> (4990 ft<sup>2</sup>) and a maximum height of 4.6 metres.

4. The uses may be carried out subject to the following conditions and specifications shown on Schedules 'B', 'C', 'D', 'E', 'F' and 'G' attached to and forming part of this permit:

**General**

- a) The uses permitted in Section 2. (above) may not result in any contamination or degradation of the groundwater aquifers in the vicinity of the subject property or downstream aquatic areas.
- b) All vehicles, equipment, buildings and materials permitted by Section 2. and 3. (above) are to be removed from the site by the date of the expiry of this permit. The removal of screening is not a condition of this permit.
- c) Unless a rezoning application is received by the Islands Trust, upon the expiry of this permit, the Temporary Permit Area of the property shall be remediated to return to the condition prior to the commencement of the concrete batch plant operation in 2016.
- d) The maximum volume of concrete produced each month is limited to 382 m<sup>3</sup> (500 yd<sup>3</sup>).
- e) The maximum volume of aggregates stored on site is limited to 2294 m<sup>3</sup> (3000 yd<sup>3</sup>).
- f) Storage and use of motorized and non-motorized vehicles and equipment accessory to the uses permitted in Section 2. (above), and motorized vehicles are further limited as follows:
  - i. Two (2) dump truck;
  - ii. One (1) 'pup' loader;
  - iii. Two (2) 'pup' trailers';
  - iv. Three (3) excavators;
  - v. One (1) Tractor with low-bed trailer,
  - vi. Four (4) concrete trucks; and,
  - vii. A maximum of two (2) other vehicles

**Access and Hours of Operation**

- g) Vehicle access to and from the Temporary Use Area shall be restricted to the use of only one of the two access point on Bedwell Harbour Road at any given time as indicated on Schedule 'A'.
- h) Both vehicular access driveways shall be surfaced with road base (or similar) extending a minimum of 75 metres from Bedwell Harbour Road, and the surface shall be maintained for the duration of the permit and any renewal period.
- i) There is to be no public access to and from the concrete batch plant area of the Temporary Use Area Site.
- j) The specific area containing wastewater holding tanks shall be guarded with a locked, non mountable fence to a height of 1.8 metres to prevent access.
- k) The specific area containing retention pond (overflow) shall be guarded with locked, non mountable fence to a height of 1.8 metres to prevent access.
- l) Hours of operation, including movement of vehicles and equipment, are restricted to between 8:00 a.m. and 4:30 p.m., Monday to Friday.
- m) Hours of operation, including movement of vehicles and equipment, are restricted to between 9:00 a.m. and 3:00 p.m. on Saturdays with no more than two (2) deliveries on any Saturday and where all reasonable measures are taken to abate noise.

- n) Hours of operation may be extended to between 5:00 a.m. and 7:00 p.m., Monday to Friday exclusively for off-island loads as necessarily determined by ferry schedules and where all reasonable measures are taken to abate noise.

***Water and Waste Management***

- o) All paved surfaces within the 'concrete batching area' as shown on Schedule 'A' are to be bounded by a 150 mm x 150 mm extruded curb with a minimum reverse 1% grade for wastewater capture and collection in accordance with the specifications shown on Schedule 'C'.
- p) The lined secondary containment area for the wastewater holding tanks is to be lined and maintained with a minimum 45 mil. rubber pond liner.
- q) Surface water not related to concrete production shall be directed away from wastewater collection areas.
- r) Siltation control is to be installed to prevent the release of any suspended materials in surface runoff from the Temporary Use Area within all site ditching as shown on Schedule 'A' and specified in Schedule 'C' attached to and forming part of this permit.
- s) Dust control measures shall be implemented in accordance with the "Recommended Guidelines for Environmental Management Practices for Canadian ready Mixed Concrete Industry" as excerpted on Schedule 'D'.
- t) All waste concrete shall be disposed of through creating concrete "loc-blocks" on site.
- u) Aggregates stored on-site shall be contained within areas delineated along three sides with concrete "loc-block" walls measuring a maximum height of two (2) blocks (1.5 m).
- v) Aggregates stored on-site shall be covered with secured tarps in good condition to prevent leachates caused by rainfall.
- w) The operator shall ensure that wastewater / excess concrete has been treated / covered / stored within a sealed vessel (10,000 gallon tank) ahead of rain fall.

***Hydrocarbon Management***

- x) Storage of chemicals and hydrocarbons is to be contained in corrosion-resistant tanks securely anchored on flat surfaces.
- y) Storage of chemicals and hydrocarbons is to be contained in a locked, weather protected (roofed) structure ('sea container') with a 15.25 cm (6 in.) "kick plate" as shown on Schedule 'A'.
- z) Containment for chemicals and hydrocarbons within the seacan is to be contained in a lined cell providing a minimum of 120% of the volume of stored liquids.
- aa) Emergency spill kits are to be provided at all areas where chemicals and/or fuel is stored.

***Landscape & Screening***

- bb) The earthen berms planted with Douglas fir and speria as shown on Schedule 'F' and described in Schedule G must be maintained and irrigated as necessary to assist in survival for the entire period of the temporary use permit.
- cc) The berms are to be maintained in a roughened state and contoured to an angle of 3H:1V to prevent runoff.

### ***Groundwater Monitoring***

- dd) A groundwater monitoring well shall be installed down gradient from the concrete batch plant and water management area within one (1) year of the issuance of this permit to allow for monitoring of groundwater quality resulting from TUP activities.

### ***Environmental Management Plan and Reporting***

- ee) The uses permitted in Section 2. (above) shall conform to all operational methods, environmental mitigation measures, best management practices and environmental monitoring requirements contained in the "Environmental Management Plan" ('EMP' - Islander Engineering Ltd., October 2019) and submitted to the Islands Trust, Victoria Office on October 3, 2019.

### ***Monitoring***

- ff) The 'Monitoring Environmental Consultant' shall be Islander Engineering Ltd. or a qualified professional licenced in the Province of BC with relevant experience in Environmental Management and hydrogeology.
- gg) The Monitoring Environmental Consultant shall prepare and submit to the Islands Trust a monitoring report on adherence to the 'Environmental Management Plan' within one (1) year of the issuance of this permit, and that report shall include a completed checklist as shown on Schedule 'E', attached to and forming part of this Permit.
- hh) The Islands Trust Bylaw Enforcement Officer may enter the property between the hours of 9:00 am and 5:00 pm on any day without prior consultation with the holder of the Permit for the purpose of investigating a complaint.

### ***Rezoning Application Submission***

- ii) The property owner shall submit a rezoning application to the North Pender Island Local Trust Committee for the long-term operation of the concrete batch plan on the property within six (6) months of the issuance of the permit or this permit shall cease to be valid.
5. Pursuant to Section 502 of the *Local Government Act*, the Local Trust Committee requires security to ensure that any damage to the natural environment resulting from the contravention of a condition of this permit is corrected:
- a) Where the Local Trust Committee considers that a condition in the permit has been contravened resulting in damage to the natural environment, the Local Trust Committee may undertake and complete the works required to correct the damage to the natural environment, at the cost of the permit holder, and may apply the security in payment of the cost of the works with any excess to be returned to the permit holder.
  - b) Any interest earned on the security provided under Condition 5.c.i shall accrue to the permit holder and be paid to them immediately on return of the security or, on default, become part of the amount of the security.

- c) The security provided by the permit holder shall be in the form of:
    - i. An irrevocable letter of credit with a clause for automatic renewal, or cash equivalent;
    - ii. Payable to the Islands Trust; And,
    - iii. In the amount of \$10,000.00
  - d) Where the use authorized by this permit has ceased; or a rezoning application has been received by the Islands Trust; or the permit has expired and the use on the land ceased prior to commencement of any work pursuant to this permit, the security shall be returned to the permit holder, minus any funds still required to satisfy the Condition 5.a of this permit, provided that the conditions have been met.
6. This permit is valid for three (3) years from date of issuance of the permit and upon expiry of the permit the owner of the site shall discontinue the temporary use to the satisfaction of the Islands Trust, or apply for a renewal of this permit.
7. This permit is not a building permit and does not remove any obligation on the part of the permittee to comply with all other requirements of "North Pender Island Land Use Bylaw No. 224, 2022", and for regulatory compliance and requirement to obtain other approvals necessary for the proposed uses with other authorities including the Provincial Ministry of Environment, Ministry of Transportation and Infrastructure, Capital Regional District, or Island Health.

**AUTHORIZING RESOLUTION PASSED BY THE NORTH PENDER ISLAND LOCAL TRUST COMMITTEE THIS 28<sup>TH</sup> DAY OF JULY, 2023.**

\_\_\_\_\_  
Deputy Secretary, Islands Trust

\_\_\_\_\_  
July 31, 2023

Date Issued

**NORTH PENDER ISLAND LOCAL TRUST COMMITTEE**  
**NP-TUP-2023.5**  
**SCHEDULE 'A'**

**SITE PLAN**

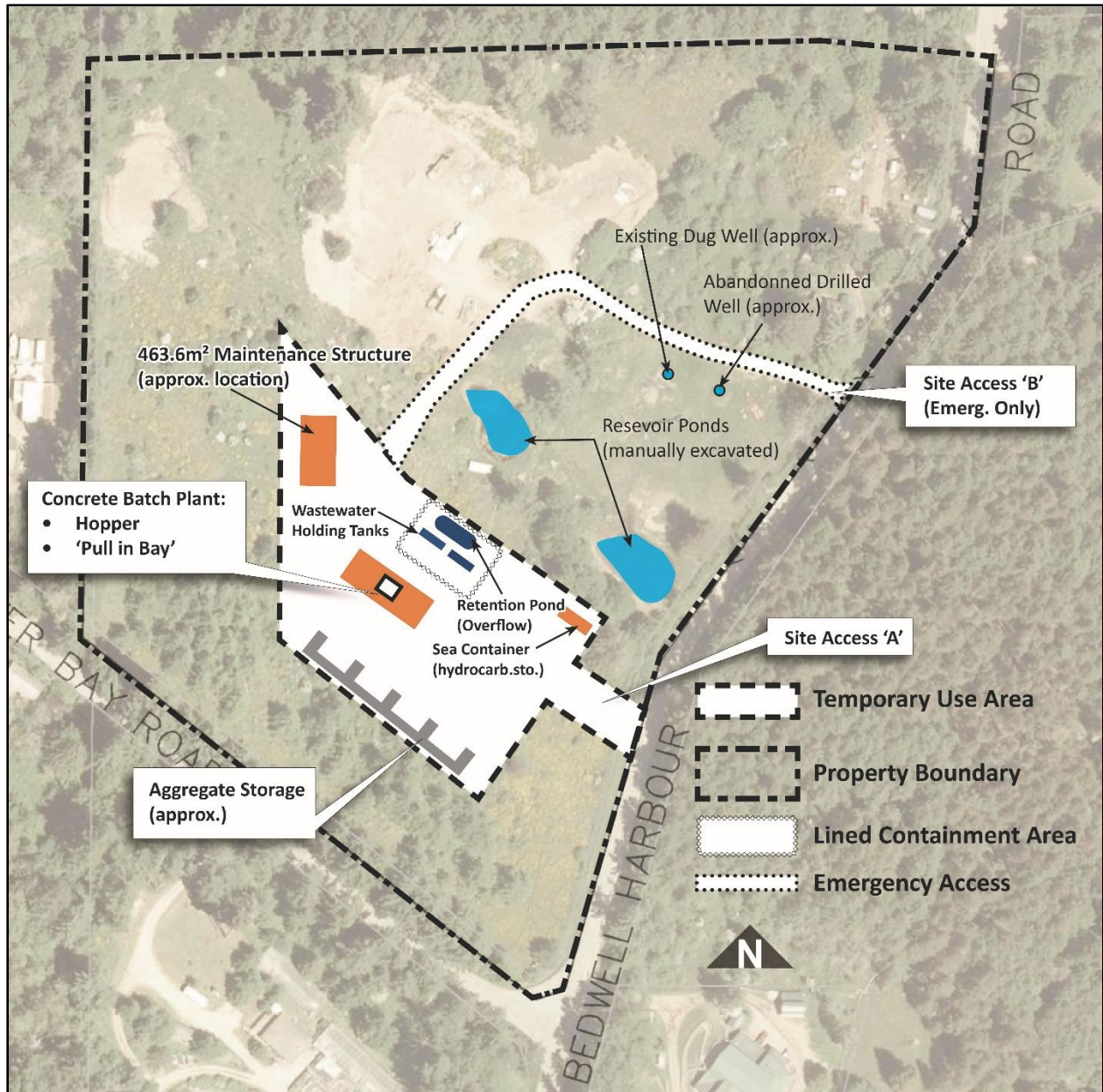

NORTH PENDER ISLAND LOCAL TRUST COMMITTEE  
NP-TUP-2023.5  
SCHEDULE 'B'

CURB CROSS SECTIONS

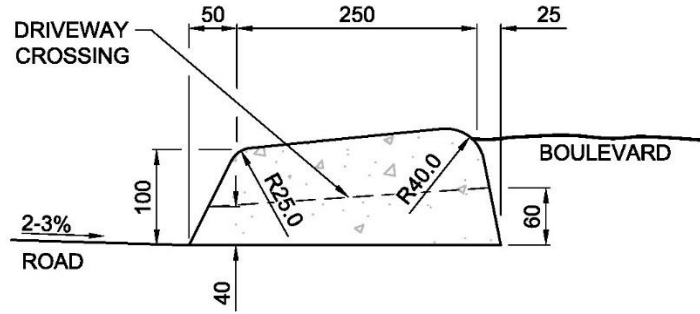

TEMPORARY CONCRETE CURB 1

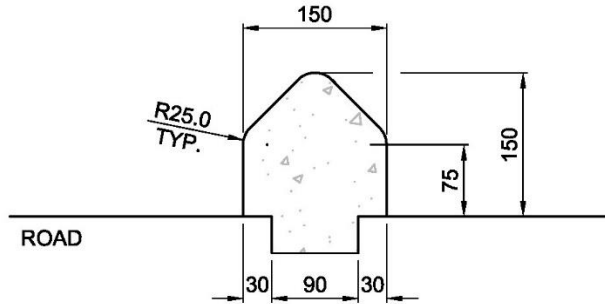

TEMPORARY CONCRETE CURB 2

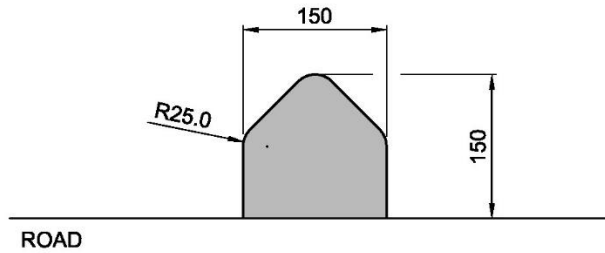

TEMPORARY ASPHALT CURB

NORTH PENDER ISLAND LOCAL TRUST COMMITTEE

NP-TUP-2023.5

SCHEDULE 'C'

SILT FENCE SPECIFICATIONS

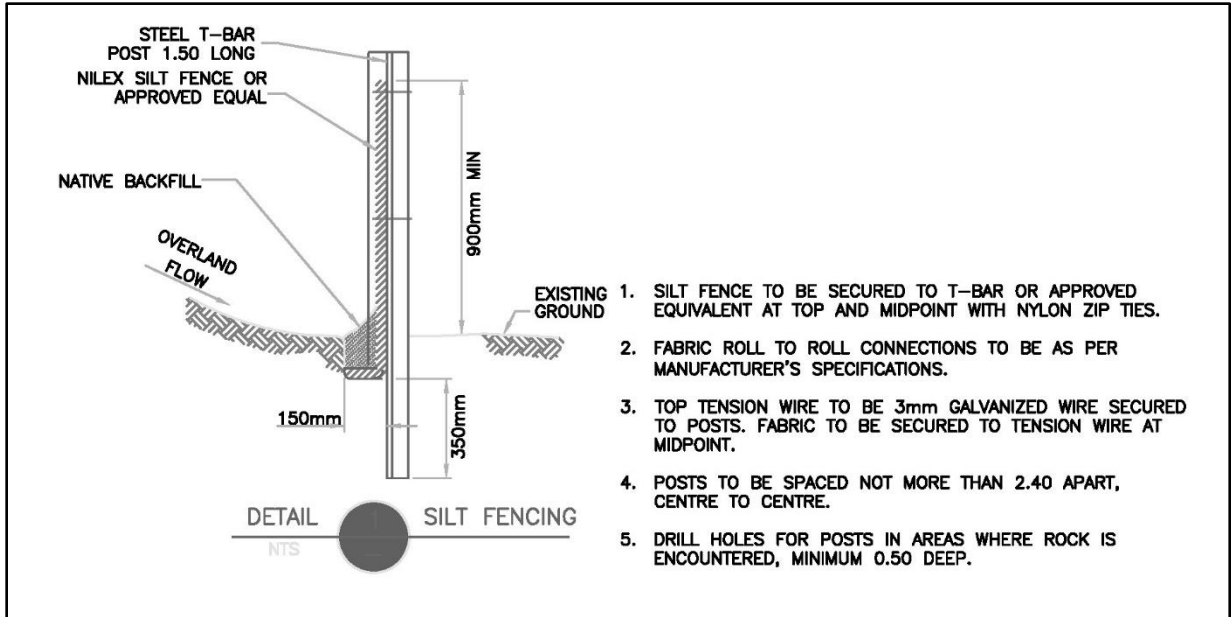



## NORTH PENDER ISLAND LOCAL TRUST COMMITTEE

### NP-TUP-2023.5

### SCHEDULE 'D'

#### DUST SUPPRESSION

##### **MINIMIZING SOURCES FOR DUST EMISSIONS – Excerpted from 'Recommended Guidelines for Environmental Management Practices for Canadian Ready Mixed Concrete Industry'**

The plant manager's air quality management program should address the following objectives:

- Identify all sources for dust emissions that are released into the atmosphere from the plant and property by plant operations.
- Collect airborne particulates from point source dust emissions through air filtration mechanisms where practical.
- Suppress the airborne particles from fugitive source dust emissions generated from the plant and property site.
- It is important for any air quality management program to also consider local climatic conditions for the plant site, with consideration for prevailing wind directions, average daily temperatures and seasonal precipitation.

##### ***Batch Plant Operations***

The handling or transfer of aggregates and other raw materials into or within the batch plant can help minimize and eliminate batch plant dust emissions. Some alternatives for minimizing dust emissions from batch plant operations:

- Fine tune the batching sequence to deliver a smooth, controlled flow of raw material into the plant mixer
- Consider covers or partial enclosures for elevated conveyors into plant
- Enclose or shield aggregate storage areas and transfer points

##### ***Aggregate Storage and Handling***

The storage or handling of aggregates and any other raw materials around the plant site can help minimize and eliminate plant site dust emissions. Some alternatives for minimizing dust emissions from aggregates storage:

- Consider higher moisture content in aggregates delivered to yard
- Partial enclosures or below grade pads for aggregate stockpile areas
- Minimize exposed surface area of aggregate stockpiles
- Minimize number of transfer points for raw materials
- Minimize drop heights for conveyor or hoppers

##### ***Traffic Areas***

Some alternatives for minimizing dust emissions from plant site traffic:

- Consider paving or hard surfacing of high traffic areas around yard
- Keep paved or hard surfaced areas clean
- Dust suppression using water or chemical dust suppressants

##### ***Diesel Engine Exhaust Emissions***

Diesel engine exhaust systems for all fixed and mobile equipment in use at the plant site provide multiple point source emissions. As mixer trucks wait in the yard, it is important to minimize the amount of engine idling time to reduce exhaust emissions and save fuel.

Maintaining correct engine-operating temperatures also helps in reducing exhaust emissions and prolongs equipment life. A regular preventive maintenance program will keep equipment and vehicle

engines running at optimal performance. Equipment and vehicle pollution control devices should be included as part of the regular maintenance inspection.

### ***Dust Suppression***

Small water droplets, produced by water spray bars, are effective as a dust suppression measure. The dust particles cling to the small water droplets, preventing the dust particles from becoming airborne. Some best management practices for dust suppression:

- Using a water spray bar or spray ring to rinse down the charge hopper at the truck mixer load point.
- Using a water truck with spray bars for wetting down plant yard surfaces and roadways.
- Wetting down aggregate stockpiles using water spray bars or sprinklers.

These best management practices for dust suppression would also require coordination with water management for the plant site and property:

- Using spray bars for dust suppression at aggregate transfer points (e.g., at the end of the conveyor belt which charges the aggregate bins).
- Installing a soaker hose or spray bar at the plant yard entrance for mixer truck wheel wash.
- Water used for dust suppression purposes should not be allowed to mix with surface runoff from the plant property.

**NORTH PENDER ISLAND LOCAL TRUST COMMITTEE**

**NP-TUP-2023.5**

**SCHEDULE 'E'**

**CHECKLIST**

**Checklist for Compliance with Environmental Management Plan (Islander Engineering, Oct. 2019)**

<b>CONDITION/REGULATION</b>	<b>COMPLETED /COMPLIANT ( Y/N )</b>	<b>SCHEDULE DATE TO BE COMPLETED/COMMENTS</b>
<b>ENVIRONMENTAL MGMT ACT</b>		
- <b>Contaminated Sites Regulation</b>		
- <b>Fisheries Act</b>		
- <b>Waste Discharge Act</b>		
- <b>Spill Reporting Regulation</b>		
- <b>Hazardous Waste Regulation</b>		
- <b>Water Sustainability Act</b>		
<b>ASSIGNMENT OF ROLES &amp; RESPONSIBILITIES (p.5)</b>		
- <b>Supervisor</b>		
- <b>Health, Safety &amp; Environmental Representative</b>		
- <b>All Employees</b>		

<b>5. WATER MANAGEMENT</b>		
<b>5.1.1 Wastewater Reduction (BMP):</b>		
- Minimize the need for exterior truck washing by controlling dust losses from the batching area;		
- Train employees with regards to water use, ensuring that they understand the importance of controls and the possible impact to the environment and company liability;		
- Limit or eliminate freshwater use by recycling processed water and using captured storm water runoff wherever possible; Reduce total water usage during drum washout by using multiple small rinses, rather than large volume single rinses;		

CONDITION/REGULATION	COMPLETED /COMPLIANT ( Y/N )	SCHEDULE DATE TO BE COMPLETED/COMMENTS
- Consider the use of hydration stabilization admixtures;		
- Consider dry washout procedures;		
<b>5.1.2 Water Collection/Containment (p.9)</b>		
- All paved surfaces within the batching area should be curbed and graded to allow for effective capture and collection of wastewater;		
- Any surface water not related to concrete production should be directed away from wastewater collection areas;		
- Equipment and vehicular traffic should be minimized through batching area where wastewater may be present;		
- Sufficient capacity must be provided for wastewater holding tanks / basins;		
- Wastewater holding tanks / basin shall be impermeable;		
- Sufficient secondary containment (i.e., berms) shall be provided to capture any overflow from wastewater holding facilities.		
- Any breaches in containment facilities that cause release of wastewater to the environment shall be considered a spill incident and spill response measures, described in Section 6, shall be followed.		

CONDITION/REGULATION	COMPLETED /COMPLIANT ( Y/N )	SCHEDULE DATE TO BE COMPLETED/COMMENTS
<b>5.2. Storm Water Runoff</b>		
<b>5.2.2 BMP:</b>		
- Encourage surface water to seep into the soil naturally;		
- Preserve natural vegetation where possible;		
- If possible, retain woody debris and organic matter on-site as mulch;		
- Roughen or terrace slopes to prevent erosion. Limit slope steepness and length to reduce runoff velocity;		
- Cover soil stockpiles and bare slopes with mulch, tarps, etc;		
- Re-vegetate or landscape disturbed areas of the Site as soon as possible. If areas of the Site must be left disturbed during the rainy seasons, sow a temporary cover crop,		
- apply mulch or lay geotextile to stabilize exposed soils;		
- Keep machinery within specific access areas. Limit the extent of machine access areas to the minimum necessary to conduct operations in a feasible and practical manner;		
- Control disposal or runoff of water containing suspended materials or other harmful substances in accordance with federal, provincial and municipal requirements;		
- If it is not possible to isolate and divert flowing water from a work area (due to water depth and volume) isolate works with a structure (e.g., silt curtain, sand bags, earthen berm, etc.) to keep silty water from leaving the Site;		

CONDITION/REGULATION	COMPLETED /COMPLIANT ( Y/N )	SCHEDULE DATE TO BE COMPLETED/COMMENTS
- Avoid clearing vegetation from work zones during snowmelt or heavy rains;		
- Isolate work / excavation areas from all flowing water;		
- Inspect all silt fences and other controls (i.e., catch basin inserts, stop logs) on a daily basis prior to the start of work and correct deficiencies immediately. Pay special attention in areas where construction activities have changed natural contours or drainage patterns to ensure that controls are properly located for effectiveness		
<b>5.3 Water Treatment</b>		
- Protocol in place for overflow incidents		

CONDITION/REGULATION	COMPLETED /COMPLIANT ( Y/N )	SCHEDULE DATE TO BE COMPLETED/COMMENTS
<b>6. CHEMICAL AND PETROLEUM HYDROCARBON MANGEMENT</b>		
<b>6.2 Storage and Handling</b>		
<ul style="list-style-type: none"> <li>- Concrete additives are currently stored within manufacturer containers within a covered, plastic sheet-lined secondary containment structure at the top of the batch plant.</li> </ul>		
<ul style="list-style-type: none"> <li>- Mechanical fluids (oils / waste oils) are stored within a transportation seacan with a welded lip at the entrance, which provides secondary containment to small jugs of hydraulic fluid within. Waste oil is stored within an above ground storage tank within a separate plastic sheet-lined cell within the seacan.</li> </ul>		
<ul style="list-style-type: none"> <li>- Fuel is stored within fuel tanks and tidy tanks aboard various vehicles and equipment throughout the Site. There is no bulk fuel storage on Site</li> </ul>		
<b>Best Management Practices</b>		
<ul style="list-style-type: none"> <li>- Locate storage facilities away from high traffic areas, with reasonable protection from vehicle / equipment damage;</li> </ul>		
<ul style="list-style-type: none"> <li>- Provide storage areas with a means (i.e., lock and key) to control access to the materials so that only authorized (e.g., trained) personnel may remove and use the materials;</li> </ul>		
<ul style="list-style-type: none"> <li>- Ensure tanks are corrosion-resistant and stable / anchored securely on a flat surface;</li> </ul>		
<ul style="list-style-type: none"> <li>- If possible, store drums and pails of related products in same area;</li> </ul>		

CONDITION/REGULATION	COMPLETED /COMPLIANT ( Y/N )	SCHEDULE DATE TO BE COMPLETED/COMMENTS
- Ensure all materials are properly labelled and remain in original containers with lid intact for as long as reasonable for Site operations;		
- Protect liquids from freezing, where applicable;		
- Provide minimum 120% secondary containment for all volumes of liquid stored;		
- Provide with a means of segregating combustible and flammable materials from oxidizing agents and other sources of ignition (i.e., away from sparks and/or with physically separated storage areas)		
- Provide with a means of preventing water reactive and pyrophoric materials from coming in contact with accumulated water (i.e., roofed enclosures)		
- Provide emergency spill kits/supplies within the storage area, including fire extinguishers, non-sparking shovels, sand bags, etc.		
<b>6.3 Disposal</b>		
- Source reduction procedure in place		
- Returns procedure in place		



CONDITION/REGULATION	COMPLETED /COMPLIANT ( Y/N )	SCHEDULE DATE TO BE COMPLETED/COMMENTS
<b>7. SPILL RESPONSE AND PREVENTION</b>		
<b>7.1 Spill Response</b>		
- Spill Response Steps reviewed by all staff (pp. 14 -16)		
- Spill Response Steps posted in appropriate areas		
<b>7.2 Spill Response Equipment</b>		
- Standard Spill Kit		
- Vehicle Spill Kit		
<b>7.3 Spill Prevention (BMP)</b>		
<ul style="list-style-type: none"> <li>- Equipment is to be inspected daily to ensure that it is leak-free and functioning as intended. All fuel/oil caps will be manually checked to ensure that they are tightened down. Equipment will be tagged out of service if found to be leaking. Servicing of equipment that is absolutely necessary on-site is to be done within containment areas (i.e., bermed or otherwise isolated) or at an appropriate work yard operated by the contractor or his supplier;</li> </ul>		
<ul style="list-style-type: none"> <li>- Equipment or machinery found to be leaking will have containment trays/buckets placed under drips/leaks that cannot be stopped (e.g., cannot be drained into an appropriate container), will have absorbent pads wrapped around leaky connections or placed under areas where a tray or bucket cannot be fitted, etc.). The person identifying the malfunction or accidental leak will notify the foreman or site supervisor, who will arrange repairs or transport off-site, and/or mechanic, if on site.</li> </ul>		

CONDITION/REGULATION	COMPLETED /COMPLIANT ( Y/N )	SCHEDULE DATE TO BE COMPLETED/COMMENTS
<ul style="list-style-type: none"> <li>- All workers/operators will be responsible for cleaning up observed leaks and/or wiping down equipment, even if the leak or spill is non-reportable.</li> </ul>		
<ul style="list-style-type: none"> <li>- Grease and oil required for maintenance will be properly applied. Excess will be cleaned up and disposed of in an environmentally appropriate manner, as will all containers, lids, and contaminated cloths and applicators.</li> </ul>		
<ul style="list-style-type: none"> <li>- During fuelling of larger compressors, light plants, etc., a portable drip tray lined with absorbent pads will be placed under the fuel tube and cap area. Absorbent pads will be used to wipe off any drips on the fuel spigot or side of equipment.</li> </ul>		
<ul style="list-style-type: none"> <li>- Jerry cans will be stored within a sealed tool box tray with lid or other suitable storage locker with ventilation, and placed in a containment tray when outside of the storage container.</li> </ul>		
<ul style="list-style-type: none"> <li>- When heavy machinery is not in use (i.e., overnight, weekends, or idle for the day), a portable drip tray will be placed under the main engine compartment.</li> </ul>		

CONDITION/REGULATION	COMPLETED /COMPLIANT ( Y/N )	SCHEDULE DATE TO BE COMPLETED/COMMENTS
<ul style="list-style-type: none"> <li>- Fire extinguishers and other emergency response equipment and supplies will be kept in known and visible locations and access to them will not be blocked by other materials or equipment. A list of emergency contacts will be posted at predetermined, accessible and visible locations, as well as kept with the emergency response equipment. By law, fire extinguishers are routinely inspected and certified, as is other fire-suppressant equipment and materials.</li> </ul>		
<ul style="list-style-type: none"> <li>- Waste oil or materials will be removed from site as soon as possible in accordance with Transportation of Dangerous Goods requirements and the BC Special Waste Regulations.</li> </ul>		
<ul style="list-style-type: none"> <li>- The Emergency Spill Response Plan will be implemented when required.</li> </ul>		
<ul style="list-style-type: none"> <li>- The Emergency Spill Response Plan will be posted on-site, and all personnel made aware of its content and location of response materials, as well as emergency contact names and numbers.</li> </ul>		
<ul style="list-style-type: none"> <li>- Oil spill response materials and equipment, such as absorbent pads, booms and leak proof containers, will be kept on-site in sufficient quantities and in an easily accessible location to contain and clean up the amount of fuel, oil or other petroleum hydrocarbons used/stored on site.</li> </ul>		

CONDITION/REGULATION	COMPLETED /COMPLIANT ( Y/N )	SCHEDULE DATE TO BE COMPLETED/COMMENTS
<b>8. MONITORING AND REPORTING</b>		
<b>8.1 Environmental Consultant</b>		
- Scheduled Follow-Up Monitoring (Wet Season)		
- Annual Monitoring		
<b>8.2 Gulf Excavating Ltd.</b>		
- Procedure for weekly Site Inspection including completion of 'Environmental Monitoring Checklist/Report' with each inspection.		

<b>Additional Comments:</b>		

NORTH PENDER ISLAND LOCAL TRUST COMMITTEE  
NP-TUP-2023.5  
SCHEDULE 'F'  
LANDSCAPE PLAN

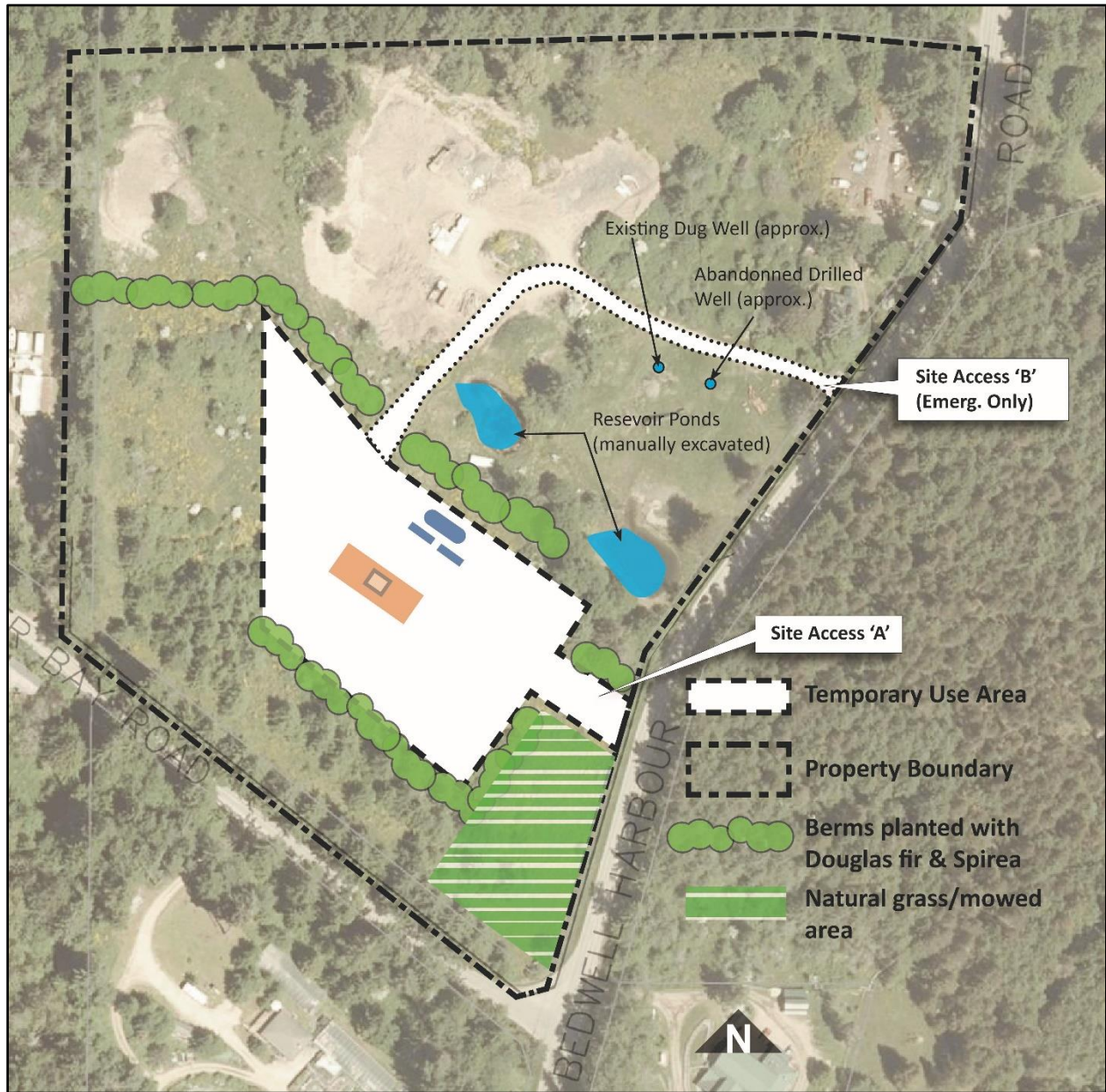

NORTH PENDER ISLAND LOCAL TRUST COMMITTEE

NP-TUP-2023.5

SCHEDULE 'G'

PLANTING SCHEME

Islandscapes

3724 Port Road, Pender Island, BC V0N 2M2 250.629.6053

July 4, 2018

Proposed Landscape Plan for Gulf Excavating Temporary Use Permit Application:

1. South and east areas bordering proposed new driveway at Bedwell Harbour Road and Otter Bay Road: restore farm pastureland by removing invasive species, primarily broom. Finish rake areas with farm equipment and seed with pasture seed mixture. Do not change existing grades or natural contours, retain native trees and shrubs. The natural contours completely screen the proposed temporary use application area from view.

2. There is a 50 foot strip below the upper pond and an adjacent 10 foot strip that should be planted to screen the temporary use application area from view from Bewell Harbour Road. These areas at base of upper pond dam to be planted with 10 *Chamaecyparis lawsonia* 5 gallon (Leyland cypress)\* on staggered 6 foot centers to provide coniferous screen **section deleted** and 15 feet away from the base of the dam to not affect the integrity of the dam. The area in front of the cypress closest to Bedwell Harbour Road to be planted with 4 *Malus fesca* 3 gallon (Pacific crab apple), 3 *Holodiscus discolor* 3 gallon (ocean spray) and 3 *Philadelphus lewisii* 3 gallon (native mock orange). Sizes are suggested, and will depend on availability. These native shrubs will soften the informal cypress hedge and allow it to act as a pollinator-attracting hedgerow. Disturbed soils to be finish raked and seeded with a low growing fescue grass mixture to hold soils while plants are established. Plantings to be screened from deer and irrigated for a period of three years.

\* Leyland cypress are fast-growing conifers that provide excellent screening. They are not native to the island. The native alternative would be *Thuja plicata* (Western Redcedar). It would not necessarily be appropriate to the area as it has higher water needs than the area will provide over time. Many of the island cedar are dying.

3. A 6 foot high solid cedar gate to be built at proposed emergency access road (existing driveway) at the entrance to the temporary use application area to complete visual screening from Bedwell Harbour Road.

4. Estimated cost:

- pull broom with excavator special attachment: 3,780.00
- finish rake and seed with farm equipment: 1,500.00
- seed: 570.00
- plant material: 1,019.20
- irrigation and screening: 450.00
- wooden gate: 1,500.00